

SWSU80-79U

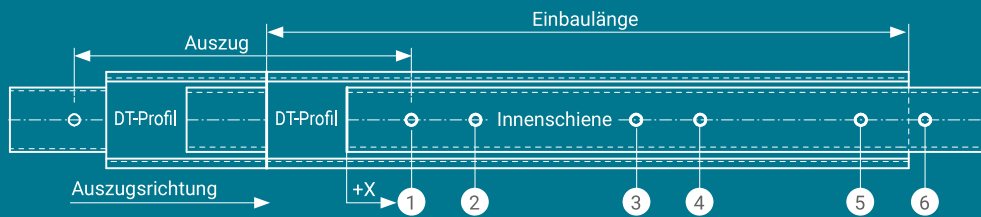

BOHRPOSITIONEN

in X, Innenschiene

Bohrung	Bohrposition	Einbaulänge
1	100 mm	immer
2	200 mm	immer
3		Ab Einbaulänge > 1000 mm
4		Ab Einbaulänge > 1000 mm
5	Einbaulänge - 200 mm	immer
6	Einbaulänge - 100 mm	immer

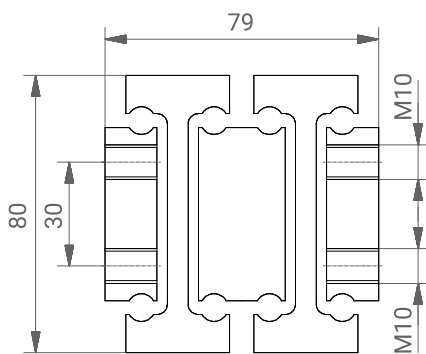

ABMESSUNGEN

Max. Last/Pair N	Eigen-gewicht kg	Auszugs-länge mm	Einbau-länge mm	Bestellnummer
6750	14,0	800	400	SWSU80-79U-400
7050	15,8	900	450	SWSU80-79U-450
7120	17,6	1000	500	SWSU80-79U-500
7250	19,3	1100	550	SWSU80-79U-550
7120	21,1	1200	600	SWSU80-79U-600
7050	22,8	1300	650	SWSU80-79U-650
7050	24,8	1400	700	SWSU80-79U-700
6730	26,3	1500	750	SWSU80-79U-750
6470	28,0	1600	800	SWSU80-79U-800
6210	29,8	1700	850	SWSU80-79U-850
5950	31,5	1800	900	SWSU80-79U-900
5690	33,3	1900	950	SWSU80-79U-950
5360	35,0	2000	1000	SWSU80-79U-1000
5135	36,8	2100	1050	SWSU80-79U-1050
4910	38,5	2200	1100	SWSU80-79U-1100
4650	40,3	2300	1150	SWSU80-79U-1150
4390	42,0	2400	1200	SWSU80-79U-1200
3870	45,4	2600	1300	SWSU80-79U-1300
3550	48,9	2800	1400	SWSU80-79U-1400
2830	52,4	3000	1500	SWSU80-79U-1500
2400	56,0	3200	1600	SWSU80-79U-1600
2200	59,5	3400	1700	SWSU80-79U-1700
2000	63,0	3600	1800	SWSU80-79U-1800
1800	66,5	3800	1900	SWSU80-79U-1900
1600	70,0	4000	2000	SWSU80-79U-2000
1500	73,5	4200	2100	SWSU80-79U-2100
1400	77,0	4400	2200	SWSU80-79U-2200
1200	80,5	4600	2300	SWSU80-79U-2300
1100	84,0	4800	2400	SWSU80-79U-2400
1000	87,5	5000	2500	SWSU80-79U-2500

WERKSTOFF

ST NX2 A

OPTIONEN Legende/Abkürzungsverzeichnis S. 5

VG LL KK NC4 FDOG VR LS

FRAGEN / KONTAKT

Telefon +49 (0)6471 3199070 oder E-Mail service@sws-technik.de