

SWSU100-98U

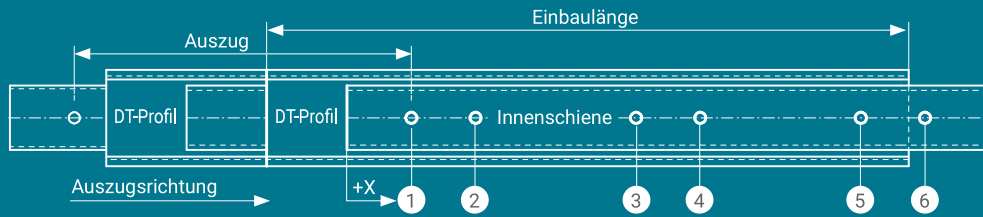

BOHRPOSITIONEN

in X, Innenschiene

Bohrung	Bohrposition	Einbaulänge
1	100 mm	immer
2	300 mm	immer
3		Ab Einbaulänge > 1000 mm
4		Ab Einbaulänge > 1000 mm
5	Einbaulänge - 300 mm	immer
6	Einbaulänge - 100 mm	immer

ABMESSUNGEN

Max. Last/Par N	Eigen-gewicht kg	Auszugs-länge mm	Einbau-länge mm	Bestellnummer
13625	30,1	1000	500	SWSU100-98U-500
14000	33,1	1100	550	SWSU100-98U-550
14150	36,1	1200	600	SWSU100-98U-600
13925	39,1	1300	650	SWSU100-98U-650
13700	42,1	1400	700	SWSU100-98U-700
13325	45,1	1500	750	SWSU100-98U-750
13025	48,2	1600	800	SWSU100-98U-800
12650	51,2	1700	850	SWSU100-98U-850
12275	54,2	1800	900	SWSU100-98U-900
11900	57,2	1900	950	SWSU100-98U-950
11600	60,2	2000	1000	SWSU100-98U-1000
11200	63,2	2100	1050	SWSU100-98U-1050
10850	66,2	2200	1100	SWSU100-98U-1100
10400	69,2	2300	1150	SWSU100-98U-1150
10175	72,2	2400	1200	SWSU100-98U-1200
9425	78,3	2600	1300	SWSU100-98U-1300
8675	84,3	2800	1400	SWSU100-98U-1400
7925	90,3	3000	1500	SWSU100-98U-1500
7000	96,3	3200	1600	SWSU100-98U-1600
6000	102,3	3400	1700	SWSU100-98U-1700
5000	108,4	3600	1800	SWSU100-98U-1800
4000	114,4	3800	1900	SWSU100-98U-1900
3250	120,4	4000	2000	SWSU100-98U-2000
2750	126,4	4200	2100	SWSU100-98U-2100
2300	132,4	4400	2200	SWSU100-98U-2200
2000	138,5	4600	2300	SWSU100-98U-2300
1750	144,5	4800	2400	SWSU100-98U-2400
1500	150,5	5000	2500	SWSU100-98U-2500

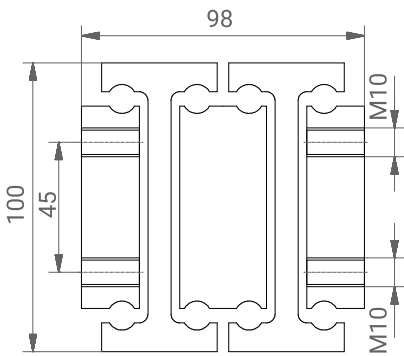

Nicht spezifizierte Abmessungen auf Anfrage

WERKSTOFF

ST NX2 A

OPTIONEN Legende/Abkürzungsverzeichnis S. 5

VG LL KK NC4 FDOG VR LS

FRAGEN / KONTAKT

Telefon +49 (0)6471 3199070 oder E-Mail service@sws-technik.de