

## SWST150-35

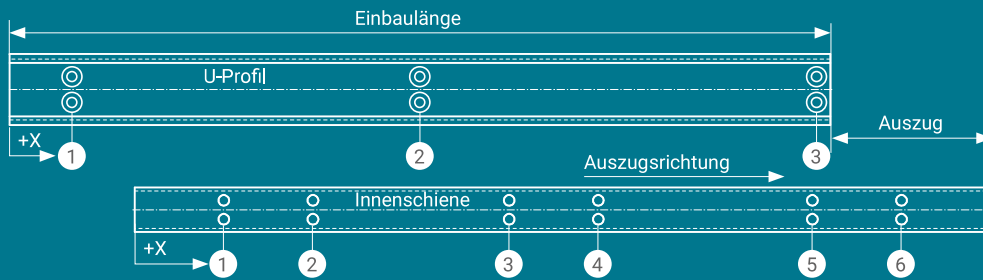

## BOHRPOSITIONEN

## in X, U-Profil

Bohrung	Bohrposition	Einbaulänge
1	50 mm	immer
2		immer
3	Einbaulänge - 20 mm	immer

## in X, Innenschiene

Bohrung	Bohrposition	Einbaulänge
1	100 mm	immer
2	300 mm	immer
3		Ab Einbaulänge > 1000 mm
4		Ab Einbaulänge > 1000 mm
5	Einbaulänge - 300 mm	immer
6	Einbaulänge - 100 mm	immer

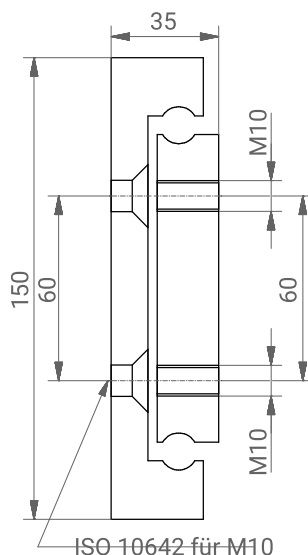

## ABMESSUNGEN

Max. Last/Pair N	Eigen-gewicht kg	Auszugs-länge mm	Einbau-länge mm	Bestellnummer
10000	17,3	300	500	SWST150-35-500
11000	19,0	350	550	SWST150-35-550
12000	20,8	360	600	SWST150-35-600
13250	22,5	390	650	SWST150-35-650
14500	24,2	420	700	SWST150-35-700
15000	25,9	450	750	SWST150-35-750
15500	27,7	480	800	SWST150-35-800
15500	29,4	510	850	SWST150-35-850
15000	31,1	540	900	SWST150-35-900
14750	32,9	570	950	SWST150-35-950
14500	34,6	600	1000	SWST150-35-1000
14300	36,3	630	1050	SWST150-35-1050
14100	38,0	660	1100	SWST150-35-1100
13800	30,3	690	1150	SWST150-35-1150
13300	41,5	720	1200	SWST150-35-1200
12500	45,0	780	1300	SWST150-35-1300
11700	48,4	840	1400	SWST150-35-1400
10900	51,9	900	1500	SWST150-35-1500
10000	55,3	960	1600	SWST150-35-1600
9100	58,8	1020	1700	SWST150-35-1700
8200	62,3	1080	1800	SWST150-35-1800
7300	65,7	1140	1900	SWST150-35-1900
6400	69,1	1200	2000	SWST150-35-2000
5500	71,9	1260	2100	SWST150-35-2100
4500	75,3	1320	2200	SWST150-35-2200
4125	79,2	1380	2300	SWST150-35-2300
3750	83,0	1440	2400	SWST150-35-2400
3375	86,5	1500	2500	SWST150-35-2500
3000	90,0	1560	2600	SWST150-35-2600
2850	93,4	1620	2700	SWST150-35-2700
2600	96,8	1680	2800	SWST150-35-2800
2500	100,3	1740	2900	SWST150-35-2900
2400	103,8	1800	3000	SWST150-35-3000

## WERKSTOFF

ST NX2 NX4 A

## OPTIONEN Legende/Abkürzungsverzeichnis S. 5

VG VO VOG LL EDG KK NC4 VR LS

## FRAGEN / KONTAKT

Telefon +49 (0)6471 3199070 oder E-Mail service@sws-technik.de