

## SWST120-31

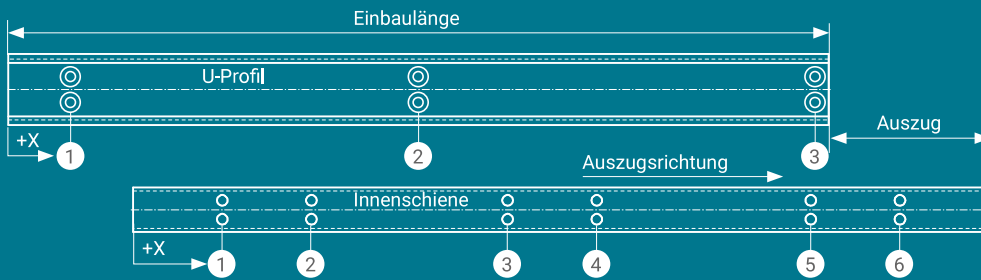

## BOHRPOSITIONEN

## in X, U-Profil

Bohrung	Bohrposition	Einbaulänge
1	35 mm	immer
2		immer
3	Einbaulänge - 15 mm	immer

## in X, Innenschiene

Bohrung	Bohrposition	Einbaulänge
1	100 mm	immer
2	300 mm	immer
3		Ab Einbaulänge > 1000 mm
4		Ab Einbaulänge > 1000 mm
5	Einbaulänge - 300 mm	immer
6	Einbaulänge - 100 mm	immer

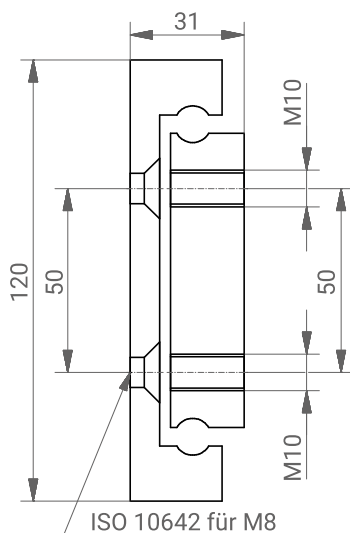

## ABMESSUNGEN

Max. Last/Paar N	Eigen-gewicht kg	Auszugs-länge mm	Einbau-länge mm	Bestellnummer
6000	9,5	240	400	SWST120-31-400
7000	10,7	270	450	SWST120-31-450
7750	11,9	300	500	SWST120-31-500
8750	13,1	350	550	SWST120-31-550
9500	14,3	360	600	SWST120-31-600
10500	15,4	390	650	SWST120-31-650
11500	16,6	420	700	SWST120-31-700
12000	17,8	450	750	SWST120-31-750
12000	19,0	480	800	SWST120-31-800
12000	20,2	510	850	SWST120-31-850
11700	21,4	540	900	SWST120-31-900
11400	22,5	570	950	SWST120-31-950
11000	23,7	600	1000	SWST120-31-1000
10900	24,9	630	1050	SWST120-31-1050
10800	26,1	660	1100	SWST120-31-1100
10550	27,3	690	1150	SWST120-31-1150
10300	28,5	720	1200	SWST120-31-1200
9800	30,8	780	1300	SWST120-31-1300
9300	33,2	840	1400	SWST120-31-1400
8700	35,6	900	1500	SWST120-31-1500
8100	38,0	960	1600	SWST120-31-1600
7400	40,3	1020	1700	SWST120-31-1700
6700	42,7	1080	1800	SWST120-31-1800
5700	45,1	1140	1900	SWST120-31-1900
4700	47,5	1200	2000	SWST120-31-2000
3700	49,4	1260	2100	SWST120-31-2100
3400	52,2	1320	2200	SWST120-31-2200
3000	54,6	1380	2300	SWST120-31-2300
2750	57,0	1440	2400	SWST120-31-2400
2500	59,3	1500	2500	SWST120-31-2500
2250	61,6	1560	2600	SWST120-31-2600
2000	64,0	1620	2700	SWST120-31-2700
1900	66,4	1680	2800	SWST120-31-2800

## WERKSTOFF

ST NX2 NX4 A

## OPTIONEN Legende/Abkürzungsverzeichnis S. 5

VG VO VOG LL EDG KK NC4 VR LS

## FRAGEN / KONTAKT

Telefon +49 (0)6471 3199070 oder E-Mail service@sws-technik.de